

Ultrascale Data Sheet

Issue: 001-060830

'ULTRASCALE' Type A Crank pin short round nut

Fitting Instructions:

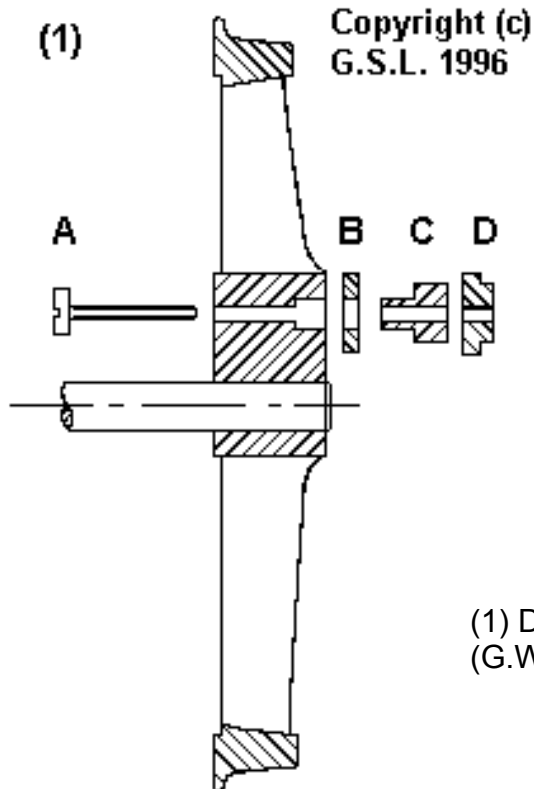

- A. 14B.A. Screw.
- B. Backing Washer.
- C. Short Crankpin Tube.
- D. Round Nut.

(1) DRIVING & TRAILING
(G.W.R. type or equivalent with round nut)

- 1 Fit backing washer over smaller diameter of crank pin tube up to shoulder.
- 2 Fit projecting small diameter backing washer and crank pin tube assembly into crank pin hole in front face of driving wheel and push home.
- 3 Fit 14 BA screw from back of wheel turning fully home with screw driver. (screw will 'self tap')
- 4 Assemble coupling rod over large diameter of crank pin tube projecting from front face of wheel.
- 5 Screw nut on thread projecting from hole in crank pin tube. (see fig. To ensure this is fitted the correct way round). Tighten and then remove surplus thread from outer face with side cutters.